

MAKING MODERN LIVING POSSIBLE

Danfoss

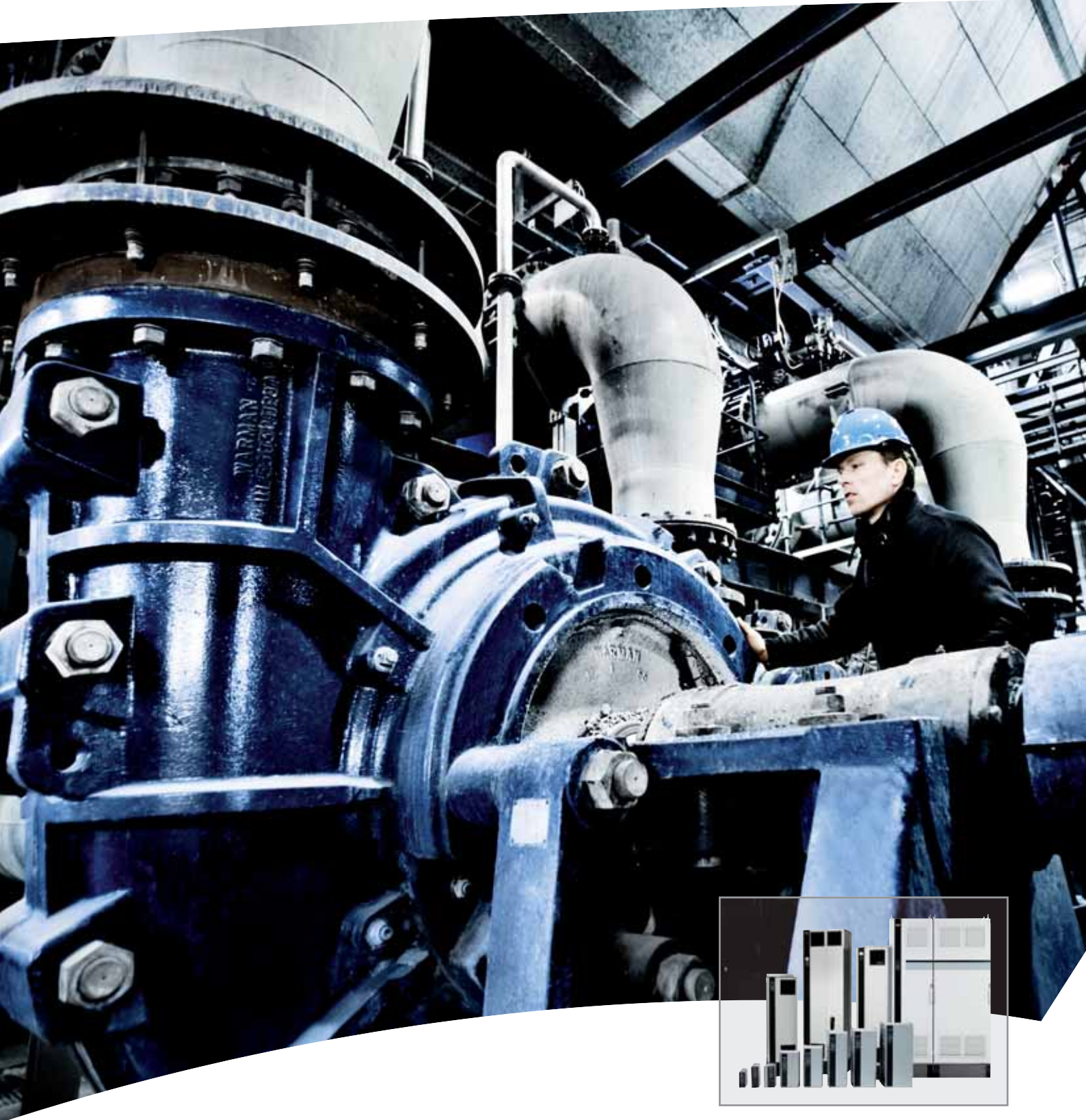

VLT® High Power Drives

VLT®
THE REAL DRIVE





VLT® performance goes up to 1.2 MW

You will find all the same qualities in the VLT® high power range that you have experienced since Danfoss put the first mass-produced drives on the market in 1968.

VLT® family

In the high power drives you will get all the advantages you are already familiar with in the lower power drives, including user-friendly commissioning and operation.

The high power range offers a host of advanced and yet easy-to-use features and options, built in and tested from factory, to meet any specification your application require.

• High efficiency

VLT® high power drives are energy efficient. 98% of the power is transferred to the motor, preventing overheating and wasted energy.

• Heat Management

Only 2% of the energy is lost through the drive. Although this is a small percentage, with large drives this heat loss must still be managed. Since VLT drives transmit

85% of the excess heat through the back-channel heat sink, it is removed from the drive, the panel, and the environment.

Only 15% of the excess heat needs to be removed from the drive electronics cabinet and control room.

• Save space

The compact design of the VLT® drives – and high power drives in particular – makes them easy to fit in even small installation spaces. Built-in filters, options and accessories facilitate this compact installation.

- Built-in DC coils for harmonic suppression eliminate need for external AC-coils.
- Optional, built-in RFI filters available in the whole power range in most series.
- Optional, input fuses and mains switch (disconnect) available with standard enclosures.
- Standard enclosures sizes available with IP 21 (NEMA 1) or IP 54 (NEMA 12) rating.

• Save time

VLT® drives are designed with the installer and operator in mind to save time in installation, commissioning and maintenance.

- Intuitive user interface includes award-winning control panel (LCP) in the new series.
- One drive type for the full power range!
- Modular VLT® design enables fast installation of options.
- Allows auto tuning of PI controllers.
- Robust design and efficient monitoring make VLT® drives maintenance free.

Have experts as partners

Danfoss Drives' unequalled drives experience combined with deep application knowledge makes our sales and service staff valuable partners, who are available for your support in 120 countries around the clock.



The modular VLT® technology platform

VLT® AutomationDrive, VLT® HVAC Drive and VLT® AQUA Drive are all built on the same modular platform allowing for highly customised drives mass produced, tested, and delivered from the factory. Upgrades and further options are a matter of plug-and-play. They share features and user interface. Once you know one, you know them all.

Programmable options

User programmable option MCO 305 for synchronising, positioning, cam control, etc.

Fieldbus options

Options for bus communication (Profibus, DeviceNet, CanOpen etc.), synchronisation, user programs, etc., are delivered ready to plug-and-play.

Display options

Danfoss Drives renowned removable Local Control Panel has an improved user interface. Choose between six built-in languages (including Chinese) or have it customised with your own. Two of the languages can be changed by the user. The info button makes the printed manual virtually redundant. Users have been involved throughout development to ensure optimum overall functionality of the drive. The user group has significantly influenced design and function of the Local Control Panel. The Automatic Motor Adaptation, the Quick Set-Up menu and the large graphic display make commissioning and operation a breeze. Choose numerical display, graphic display or no control panel.

DC coil

The renowned DC coil ensures very low harmonic disturbance of the power supply according to IEC-1000-3-2. Compact design. No need for external modules.

Encoder and I/O options

General purpose I/O.
Encoder.
Resolver.
Relay.

Hot pluggable LCP

The local control panel (LCP) can be plugged in or out during operation. Settings are easily transferred via the control panel from one drive to another or from a PC with MCT-10 set-up software.

Control signals

Specially developed spring-loaded cage clamps add to reliability and facilitate easy commissioning and service.

24 V supply

24 V supply keeps the VLT® drives logically "alive" in situations when the AC power supply is removed.

RFI

RFI available in the versions A1 and A2 according to the IEC 61000 and EN 61800 standards.

Input mains option

Various input plate configurations are available including fuses, mains switch (disconnect), or RFI filter. Input plates are field adaptable if options need to be added after the installation.

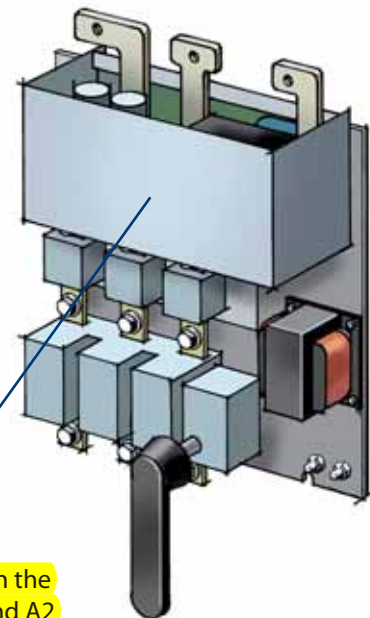
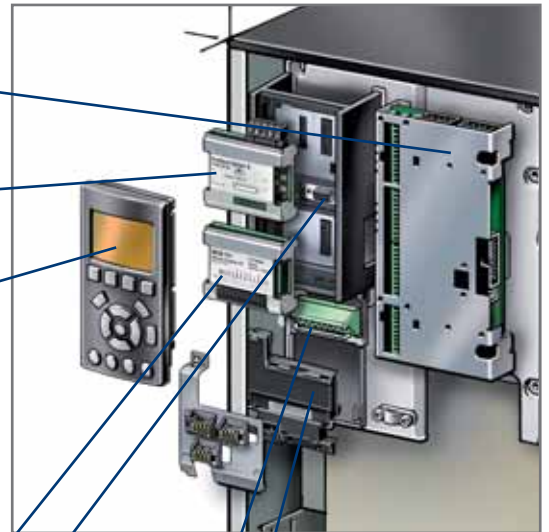

Danfoss Drives received the Frost & Sullivan Award for Product Innovation 2006 for the unique VLT® AutomationDrive series.



The new VLT® series local control panel (LCP) earned the international iF design award in 2004. The panel was chosen from a total of 1,003 entries from 34 countries in the category "interface in communication".

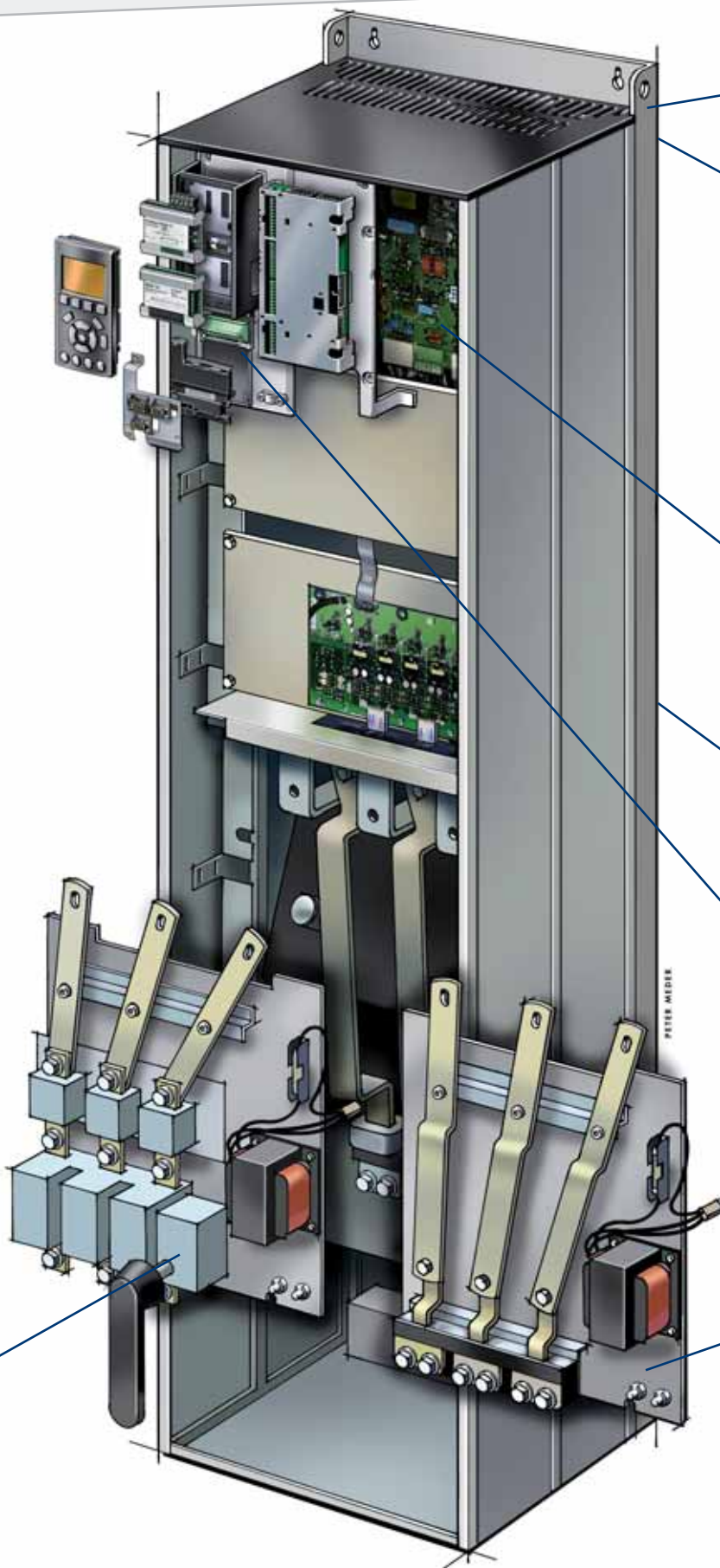

Enclosure

Depending on the installation environment, the drive is available in three enclosure configurations: IP 00/Chassis, IP 21/NEMA 1, or IP 54/NEMA 12.

Back Channel Cooling

A unique design uses a ducted back channel to pass cooling-air over heat sinks. This allows 85% of the heat losses to be exhausted directly outside of the enclosure with minimal air passing through the electronics area. This dramatically reduces temperature rise and contamination of the electronic components, improving reliability and prolonging life. There is a IP 54 seal between the back channel cooling duct and the electronics area of the drive.

Conformal coating

Conformal coated electronic components are standard per IEC 60721-3-3, class 3C2. For harsh and aggressive environments, coating as per IEC 60721-3-3, class 3C3 is an option.

Corrosive resistant

As an option, the back channel cooling duct work and heat sinks can be ordered with corrosion protection for installations in harsh environments, such as in salt-air environments near the ocean.

Safety

The new VLT® series can be ordered with safe stop functionality suitable for category 3 installations according to EN 954-1. This feature prevents the drive from starting unintentionally.

Modular Construction and Ease of Maintenance

All components are easily accessible from the front of the drive allowing for ease of maintenance and side-by-side mounting of drives. The drive is constructed with a modular approach allowing for the easy replacement of modular sub-assemblies.

Efficient high power drives

Efficiency is vital for high power drives

Efficiency was essential when Danfoss developers designed the high power drives. The electrical design and the quality of the components makes for unsurpassed energy efficiency. VLT® drives passes 98% of the supplied electrical energy on to its motor. Only approx. 2 % is left in the power electronics as heat to be removed.

Energy is saved, and electronics last longer because they are not exposed to high ambient temperatures.

Optimises motor efficiency

The VLT® feature Automatic Energy Optimisation vector technology ensures maximum magnetification of the motor, minimising passive, damaging currents and flux in the motor.

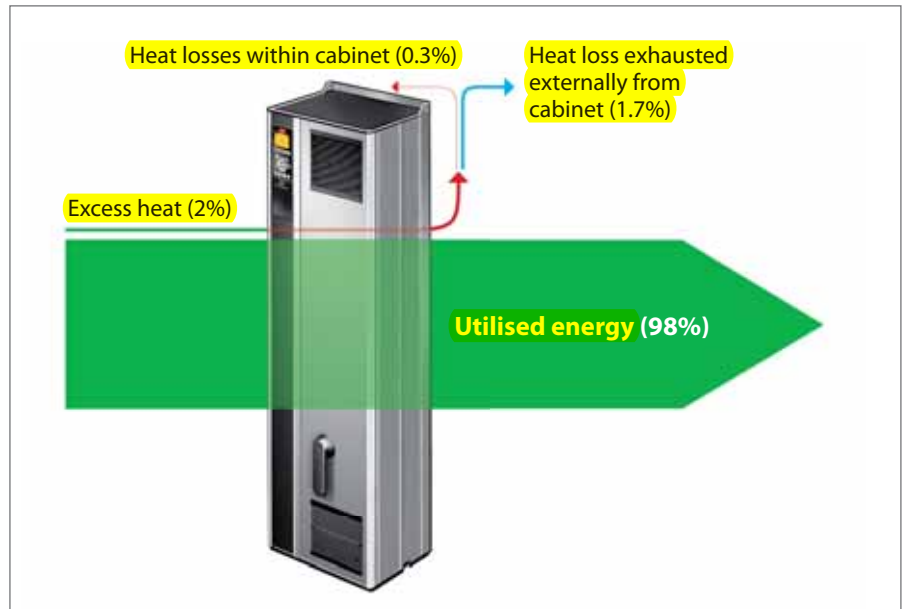

This means that maximum electrical power provided through the drive is exploited in the application.

Eliminate harmonic distortion

Danfoss active filters identify harmonic distortion from non-linear loads and injects counter phased harmonic and reactive currents to re-establish optimal sinusoidal power and a power factor = 1.

The modular build-up offers the same characteristics as the VLT® high power family, including high energy efficiency, user-friendly operation, back channel cooling and high enclosure grades.

Danfoss active filters can compensate individual VLT® drives as a compact integrated solution or be installed as a compact stand alone solution at a common point of coupling compen-

sating several loads simultaneously. Danfoss active filters can operate at medium voltage level by means of a step down transformer.

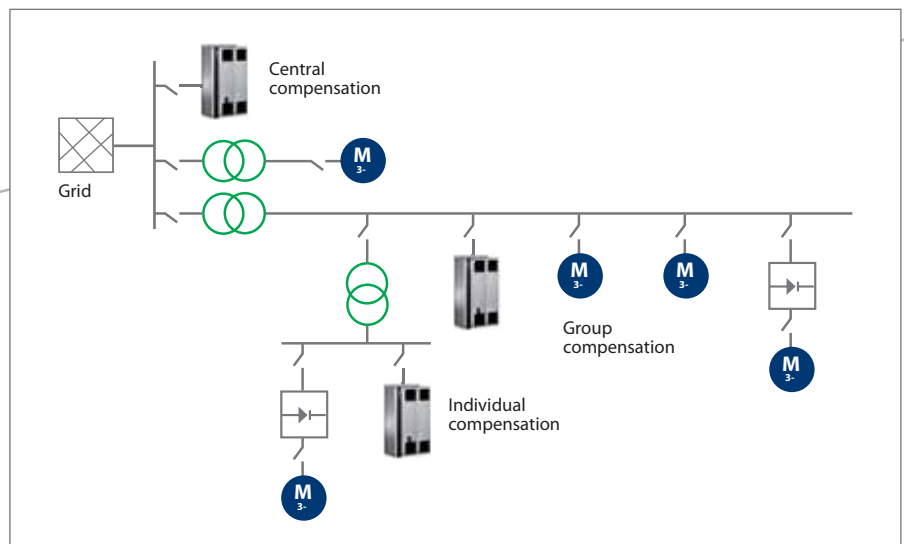

Intelligent heat management

It is vital for reliable operation that excess heat is effectively removed from the drive, the cabinet and sometimes even from the building.

The intelligent heat management of VLT® drives removes 85% of the heat losses via finned heat sinks which transfer the heat to the back channel cooling air. The heated air is then either exhausted directly into the control room or it can directly removed from the building. The remaining 15% of heat losses are removed from the control electronics area using lower volume door fans. This reduces contamination of the control electronics area resulting in longer life and higher reliability.

The excess heat is either dispersed into the control room or it is directly removed from the building.

An optional back channel cooling duct kit is available to aid in the installation of IP 00 chassis mount drives into Rittal TS8 enclosures.



Efficient heat sink cooling is a principle applied to the whole VLT® product range.



A smart, dedicated back channel cooling duct kit allows IP 00 chassis style drive enclosures to be mounted in Rittal cabinets so cool air removes 85% of excess heat without contact to the electronics.

An example

On a 6 meter wall you can place 10 drives providing 6.3 MW (at 690 V) or 4.5 MW (at 400 V).

The process heat from these drives is 126/90 kW. Mounted on an outside wall, leading the back channel cooling air directly to the outside, only 19/13.5 kW is dispersed inside the room.

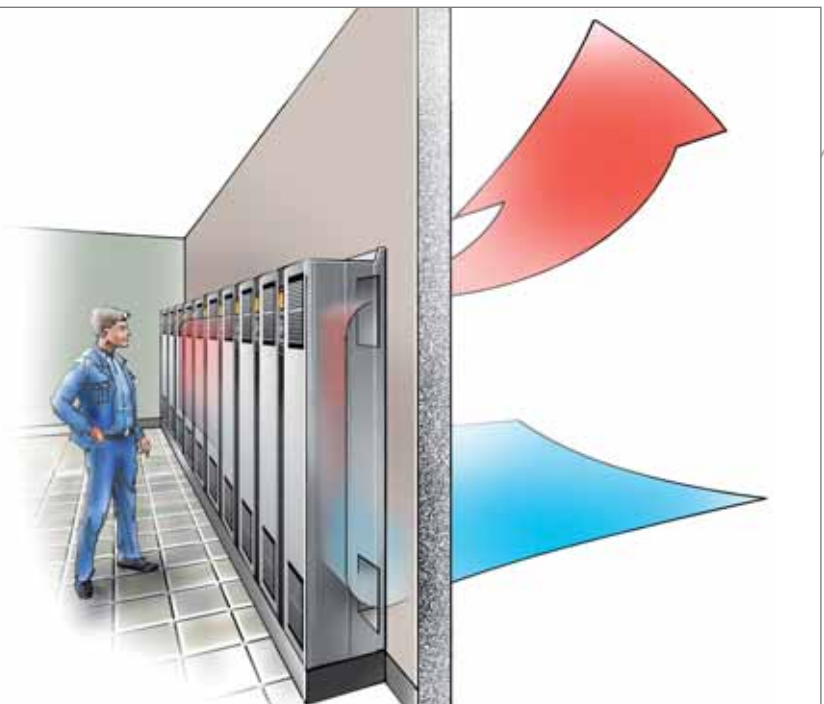

Smallest drives in their class

VLT® drives are among the smallest within their power range, and have all options built in and tested from factory.

VLT® high power drives are designed for full access from the front. Just open the cabinet door, and all components can be reached without demounting the drive – even if it is mounted side-by-side with zero distance to the neighbouring drives.

To know one is to know all

VLT® high power drives share their unsurpassed flexibility, reliability, intelligent features and renown user-friendliness with the rest of the VLT® family.

User interface, power connections and signal terminals are similar, so the VLT® drives concept is the same all over the plant.



To disconnect control signal wires, simply unplug the terminal blocks.



The fieldbus option ready to plug in beneath the front panel. It can be turned upside down if you'd rather have the cable on top.



Coated control boards are available for harsh environments.

Current and power ratings

400 VAC (380 – 440 VAC)				
Normal Overload		High Overload		Frame Size
I _N Amps	P _N kW	I _H Amps	P _H kW	
212	110	177	90	D1/D3
260	132	212	110	D1/D3
315	160	260	132	D2/D4
395	200	315	160	D2/D4
480	250	395	200	D2/D4
600	315	480	250	E1/E2
658	355	600	315	E1/E2
745	400	658	355	E1/E2
800	450	695	400	E1/E2
880	500	800	450	F1/F3
990	560	880	500	F1/F3
1120	630	990	560	F1/F3
1260	710	1120	630	F1/F3
1460	800	1260	710	F2/F4
1720	1000	1460	800	F2/F4

460 VAC (441 – 500 VAC)				
Normal Overload		High Overload		Frame Size
I _N Amps	P _N HP	I _H Amps	P _H HP	
190	150	160	125	D1/D3
240	200	190	150	D1/D3
302	250	240	200	D2/D4
361	300	302	250	D2/D4
443	350	361	300	D2/D4
540	450	443	350	E1/E2
590	500	540	450	E1/E2
678	550/600	590	500	E1/E2
730	600	678	550	E1/E2
780	650	730	600	F1/F3
890	750	780	650	F1/F3
1050	900	890	750	F1/F3
1160	1000	1050	900	F1/F3
1380	1200	1160	1000	F2/F4
1530	1350	1380	1200	F2/F4

690 VAC (551 – 690 VAC)				
Normal Overload		High Overload		Frame Size
I _N Amps	P _N kW	I _H Amps	P _H kW	
54	45	46	37	D1/D3
73	55	54	45	D1/D3
86	75	73	55	D1/D3
108	90	86	75	D1/D3
131	110	108	90	D1/D3
155	132	131	110	D1/D3
192	160	155	132	D1/D3
242	200	192	160	D2/D4
290	250	242	200	D2/D4
344	315	290	250	D2/D4
400	400	344	315	D2/D4
450	450	380	355	E1/E2
500	500	410	400	E1/E2
570	560	500	500	E1/E2
630	630	570	560	E1/E2
730	710	630	630	F1/F3
850	800	730	710	F1/F3
945	900	850	800	F1/F3
1060	1000	945	900	F2/F4
1260	1200	1060	1000	F2/F4

575 VAC (551 – 690 VAC)				
Normal Overload		High Overload		Frame Size
I _N Amps	P _N HP	I _H Amps	P _H HP	
54	50	46	40	D1/D3
73	60	54	50	D1/D3
86	75	73	60	D1/D3
108	100	86	75	D1/D3
131	125	108	100	D1/D3
155	150	131	125	D1/D3
192	200	155	150	D1/D3
242	250	192	200	D2/D4
290	300	242	250	D2/D4
344	350	290	300	D2/D4
400	400	344	350	D2/D4
450	450	380	400	E1/E2
500	500	410	400	E1/E2
570	600	500	500	E1/E2
630	650	570	600	E1/E2
730	750	630	650	F1/F3
850	950	730	750	F1/F3
945	1050	850	950	F1/F3
1060	1150	945	1050	F2/F4
1260	1350	1060	1150	F2/F4

I_N Amps = Continuous output current with normal overload (110%)
 P_N kW = Typical shaft output with Normal overload in kilowatts
 P_N HP = Typical shaft output with Normal overload in horse power
 Intermittent duty rated for 110% of continuous current for normal overload (for 60 sec).

I_H Amps = Continuous output current with high overload (150%)
 P_H kW = Typical shaft output with high overload in kilowatts
 P_H HP = Typical shaft output with High Overload in horse power
 Intermittent duty rated for 150% of continuous current for high overload (for 60 sec).

IP 21 (NEMA 1) and IP 54 (NEMA 12) Enclosures Dimensions

Frame	Height		Width		Depth	
	mm	inches	mm	inches	mm	inches
D1	1209	47.6	420	16.5	380	15.0
D2	1589	62.6	420	16.5	380	15.0
E1	2000	78.7	600	23.6	494	19.4
F1	2204	86.8	1400	55.1	606	23.9
F3	2204	86.8	2000	78.7	606	23.9
F2	2204	86.8	1800	70.9	606	23.9
F4	2204	86.8	2400	94.5	606	23.9

Chassis IP 00 Dimensions

Frame	Height		Width		Depth	
	mm	inches	mm	inches	mm	inches
D3	1046	41.2	408	16.1	375	14.8
D4	1327	52.2	408	16.1	375	14.8
E2	1547	60.9	585	23.0	498	19.6

Max. motor cable length

Screened150 m (500 feet)
 Unscreened300 m (1000 feet)

VLT® AutomationDrive	VLT® AQUA Drive	VLT® HVAC Drive
CanOpen		BACNet
	Smart Logic Controller	
	Built in DC coils	
	Profibus DP/V1	
	DeviceNet	
	Modbus RTU	
	EtherNet	
	Digital I/O, incremental encoder, absolut encoder, Sin/Cos encoder, resolver, application specific menus, preventive maintenance scheduling	

Ambient Temperature

(see design guide for temperature derating curves to 55° C max)

High Overload:

-10° C to 45° C maximum with 40° C 24-hour average maximum

Normal Overload:

-10° C to 40° C maximum with 35° C 24-hour average maximum

Products



VLT® AutomationDrive

An extremely flexible and cost-effective drive suitable for all industry applications – from simple speed control to dynamic servo applications.

VLT® HVAC Drive

The VLT® HVAC Drive continues Danfoss leadership in dedicated HVAC features and applications for drives. Advancements in energy monitoring, trending, system maintenance and operation are combined with a modular platform to make the drive “child’s play” to operate.

VLT® AQUA Drive

VLT® AQUA Drive is the perfect match for pumps and blowers in modern water and wastewater systems.



VLT® Harmonic Filter AHF 005/010

Easily & Effective Harmonic distortion reduction by connecting the AHF 005/010 harmonic filter in front of a Danfoss frequency converter.

- AHF 005 reduces total harmonic current distortion to 5%
- AHF 010 reduces total harmonic current distortion to 10%
- Small compact housing that fits into a panel
- Easy to use in retrofit applications
- User-friendly start-up – no adjustment necessary
- No routine maintenance required



Sine-wave and dU/dt Filters

Sine-wave and dU/dt filters reduce motor insulation stress and switching acoustic noise from the motor. Bearing currents are also reduced, especially in larger motors. dU/dt filters cut-off frequencies above the switching frequency on the motor terminal phase-to-phase voltage.

Range
3 x 200 – 500 V
3 x 525 – 690 V

Advantages:

- Protects the motor against dU/dt stress which prolongs the lifetime
- Lower the frequency depending losses in the motor, eddy current losses and stray flux losses

- Diminishing acoustic switching noise on the motor
- Reduces semi conduct losses in the drive with long motor cables
- Decrease electromagnetic radiated emissions on unshielded motor cables
- Reduce voltage peaks
- Reduce electrical discharges in the motor construction thus prolonged bearing life time



VLT® Advanced Active Filter AAF 004

Danfoss active filters are a flexible solution for both harmonics mitigation and power factor correction. Built on our drive platform and extensive knowledge in controls, the active filter offers a reliable and user friendly solution.

Range:
190-500A@400V
140-360A@690V
– higher by paralleling

The perfect solution for

- Restoring weak networks
- Increasing network capacity
- Increasing generator power
- Meeting compact retrofit demands
- Securing sensitive environments
- Utilising energy savings



VLT® Motion Control Tool MCT10

For managing drive parameters in systems the new Motion Control Tool MCT10 is the perfect tool to handle all drive-related data.

The MCT10 offers you:

- Project orientation, one file that contains all parameters settings plus user-defined documents
- Explorer like view, gives the user a low learning curve
- VLT® Motion Control Tool offers programming of synchronisation and positioning in same environment: one PC tool for all tasks

- Online and offline commissioning
- Support of different interfaces: RS485, RS232, USB and Profibus (plus more to come)
- Import of drive setting from Windows and DOS version of Dialog
- Internet download: www.danfoss.com/drives

VLT® Energy Box

– comprehensive energy analysis tool, shows the drive payback time

MCT 31

– harmonics calculations tool

Service you can rely on 24/7 – around the world

Sales and Service Contacts worldwide

Helping to optimise your productivity, improve your maintenance, and manage your finances.

- 24/7 availability
- Local hotlines, local language and local stock

The Danfoss service organisation is present in more than 100 countries. It is ready to respond whenever and wherever you need, around the clock, 7 days a week.

Find your local expert team on www.danfoss.com/drives

Pick your dedicated solution from the VLT® service menu:

Keep you running

- Current drives update
- Commissioning and regular adjustments
- Preventive maintenance

Service features

- 24/7 availability
- Hotline
- Onsite-repair
- Certified repair with warranty
- Start-up and commissioning
- Application experts
- Training
- Harmonic survey
- Preventive inspection
- Optimisation and retrofit
- Installed base evaluation
- Stock maintenance and consignment
- Extended warranty
- Agreed response time
- Fixed repair and maintenance cost
- Drives Upgrade Program

Benefits

- The base for efficient use of your resources and Danfoss Drives assets
- Quick response time
- Reduced impact on production
- More reliable production
- Improved maintenance
- Increased performance with on-time failure free operation
- Optimise performance
- Reduced lifecycle cost
- Trained resources for optimal design and maintenance
- Prevent failure
- Optimise performance
- Reduce downtime
- Lower maintenance cost
- Life-cycle optimisation
- Reduced capital and space bindings
- Optimised availability
- Optimised availability with effective finance planning
- Predictable budget for repair cost
- Minimising downtime
- Effective finance planning for maintenance
- Long-term finance planning for technology upgrade of drives

Keep you fit

- Training
- Stock maintenance & consignment
- Harmonic Survey
- Environmental Disposal

Fix your costs

- Fixed Price
- Post warranty agreement
- Transport insurance
- Response time





Environmentally responsible

VLT® products are manufactured with respect for environment, safety and well-being.

All activities are planned and performed taking into account the individual employee, the work environment and the external environment. Production takes place with a minimum of noise, smoke or other pollution and environmentally safe disposal of the products is assured.

UN Global Compact

Danfoss has signed the UN Global Compact on social and environmental responsibility and our companies act responsibly towards local societies.

EU Directives

All factories are certified according to ISO 14001 standard. All products fulfil the EU Directives for General Product Safety and the Machinery directive. Danfoss Drives is, in all product series, implementing the EU Directive concerning Hazardous Substances in Electrical and Electrical Equipment (RoHS) and is designing all new product series according to the EU Directive on Waste Electrical and Electronic Equipment (WEEE).

Impact on energy savings

One year's energy savings from VLT® drives will save the energy equivalent to the energy production from a power plant. Better process control at the same time improves product quality and reduces waste and wear on equipment.

What VLT® is all about

Danfoss Drives is the world leader among dedicated drives providers – and still gaining market share.

Dedicated to drives

Dedication has been a key word since 1968, when Danfoss introduced the world's first mass produced variable speed drive for AC motors – and named it VLT®.

Two thousand employees develop, manufacture, sell and service drives and softstarters in more than one hundred countries, focused only on drives and softstarters.

Intelligent and innovative

Developers at Danfoss Drives have fully adopted modular principles in development as well as design, production and configuration.

Tomorrow's features are developed in parallel using dedicated technology platforms. This allows the development of all elements to take place in parallel, at the same time reducing time to market and ensuring that customers always enjoy the benefits of the latest features.

Rely on the experts

We take responsibility for every element in our products. The fact that we develop and produce our own features, hardware, software, power modules, printed circuit boards, and accessories is your guarantee for reliable products.

Local backup – globally

VLT® motor controllers are operating in applications all over the world and Danfoss Drives' experts located in more than 100 countries are ready to support our customers with application advice and service wherever they may be.

Danfoss Drives experts don't stop until the customer's drive challenges are solved.

